

SCENICLIVING SLATTED CLADDING

INSTALLATION INSTRUCTIONS



ScenicLiving

By **BMARCHITECTURAL**

SCENICLIVING SLATTED CLADDING COMPONENTS

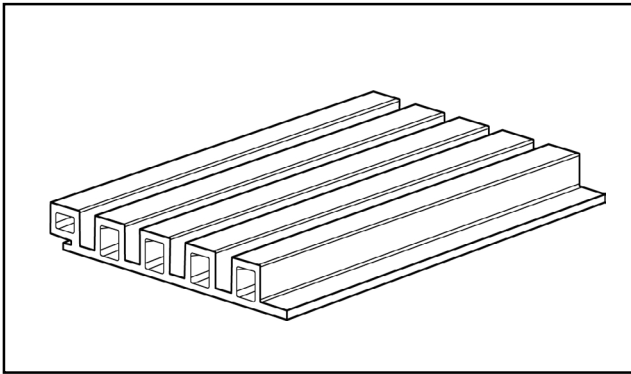

Slatted Cladding Board

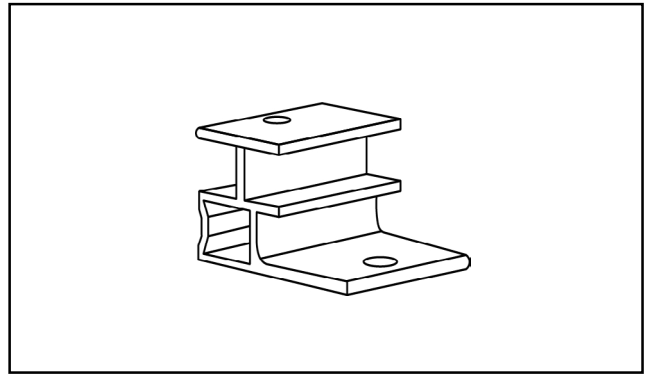

Aluminium Cladding Clip

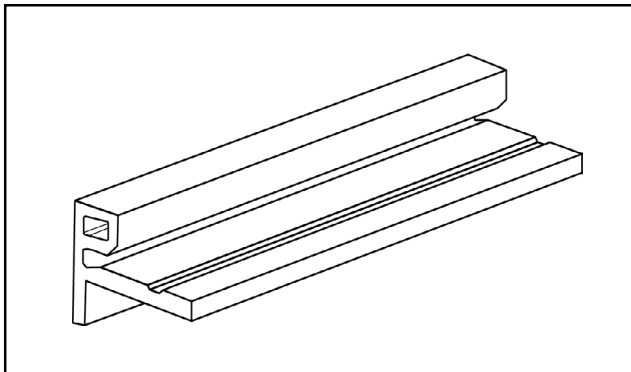

End Trim

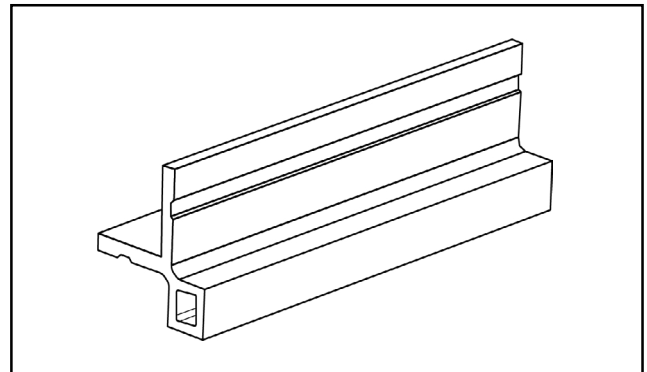

Corner Trim

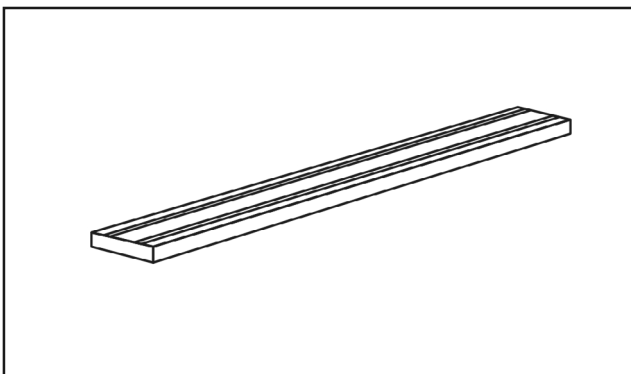

Flat Trim

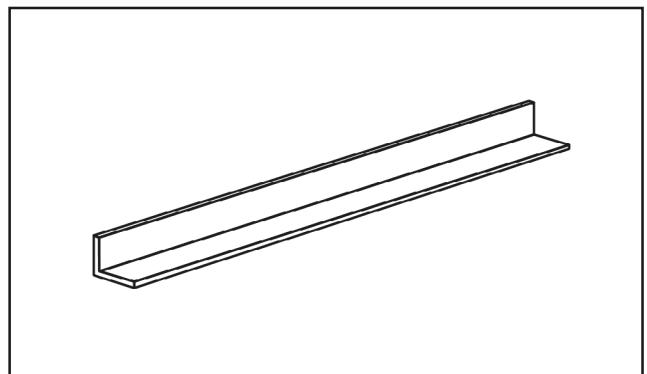

Angle Trim

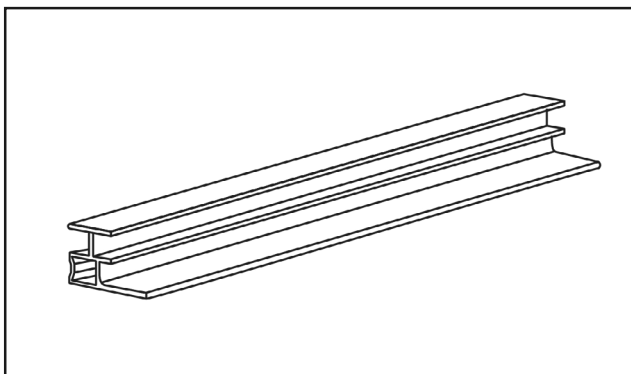

Aluminium Starter Bar

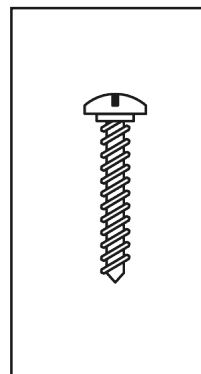

Wood Screws

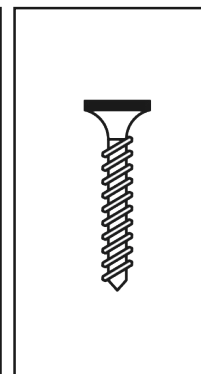

Coloured Screws

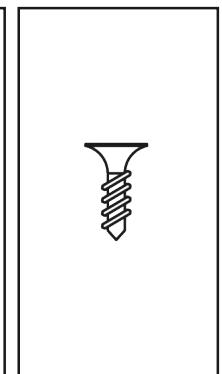

Locking Screws

HANDLING

- When unloading, place cladding boards down gently
- Always lift and lower boards with care to prevent surface damage
- Carry boards on their edge and hold from the centre
- Never drag boards across each other
- Avoid dragging tools or equipment across the board surfaces
- Keep cladding surfaces clean and free from debris throughout installation
- BM Architectural is not liable for any damage caused by improper handling

STORAGE

- Keep materials stored in a shaded, sheltered area and protected from the elements until installation begins
- Ensure materials remain dry and clean by covering them appropriately. Avoid storing products outdoors or using plastic sheeting for cover
- Boards should be supported above ground level at 500mm maximum intervals using a flat, clean surface. Make sure supports are aligned vertically through the stack to evenly distribute the weight
- Cladding boards must be stacked directly on top of each other
- If multiple pallets are delivered, do not stack more than 3 metres high
- BM Architectural is not liable for any damage caused by improper storage

TOOLS

ScenicLiving Slatted Cladding can be installed using standard woodworking tools. These include:

- Circular Saw – A multipurpose blade suitable for aluminium or laminate with 60 teeth or more, for clean, precise cuts
- Mitre Saw – Particularly handy for making accurate angled cuts
- Jigsaw – Ideal for detailed or curved cuts when needed
- Hand Drill, 3mm Drill Bit and Countersink Bit – Essential for fixing components securely and professional finishing

Other recommended equipment includes Tape Measure, Set Square, String Line, Spirit Level and Pencil.

Always wear Personal Protective Equipment, including protective eyewear throughout installation.

MAINTENANCE

To keep ScenicLiving Slatted Cladding looking its best, routine cleaning is recommended to clear away any accumulated dirt. Ideally, the cladding should be washed every six months. You can do this using either of the following methods:

- Jet wash or pressure clean with a fan nozzle, held at least 20cm away, and move along the line of the boards
- Brush with a general-purpose cleaner mixed with water

SUPPORTING STRUCTURE

We recommend support battens of either recycled plastic (available from BM Architectural), pressure treated wood or aluminium. Cladding boards should be fixed to the supporting structure at maximum 500mm centres. Extra care is required in order to provide sufficient support in and around obstacles such as windows, fascia, soffits, guttering, ventilation points etc.

Below is an example of the layers that would occur in a typical installation, but a professional should be consulted prior to any installation.

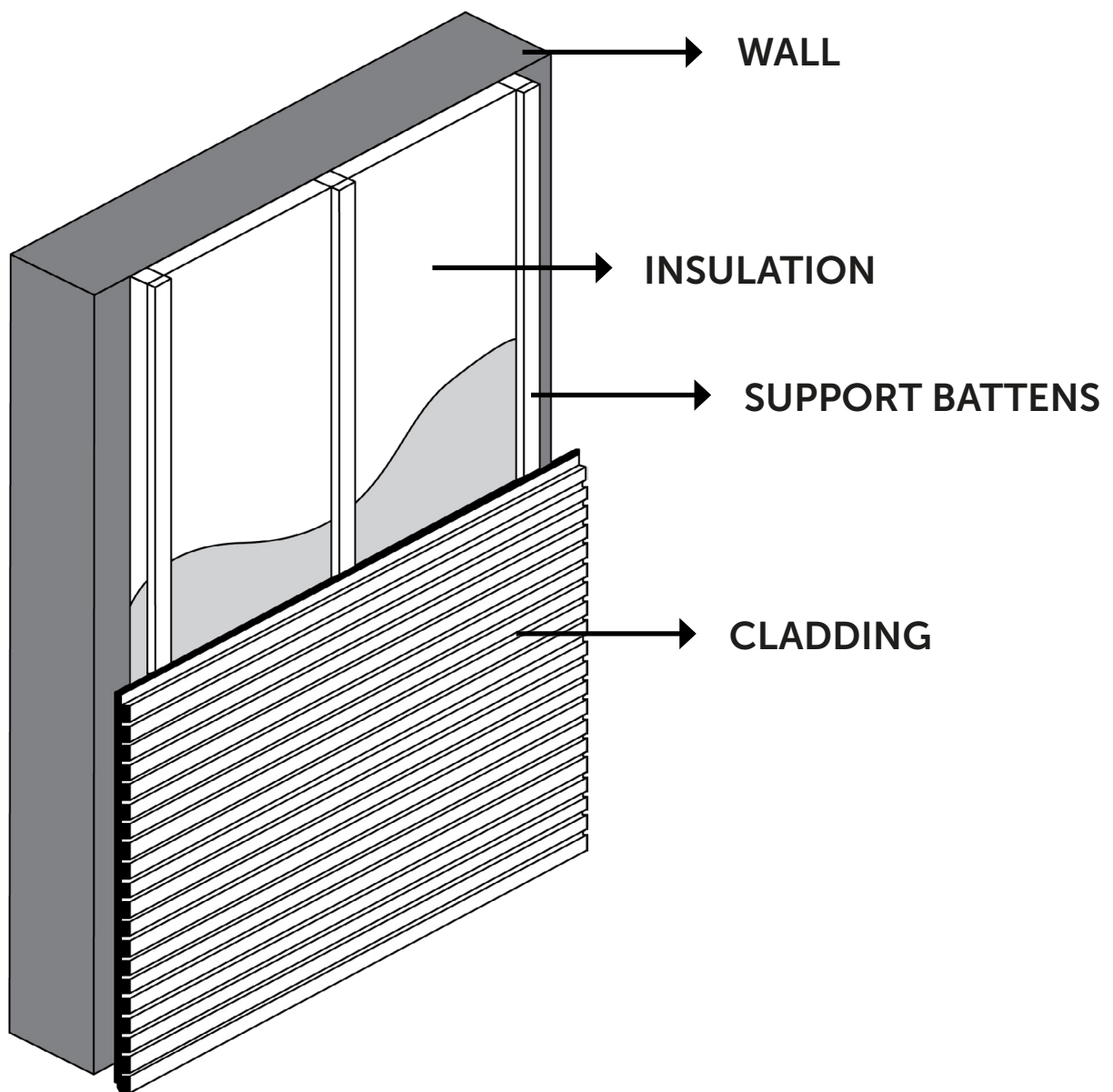

BATTEN INSTALLATION

A building professional should be consulted regarding vapour barriers and insulation for your project. Where a vapour barrier is to be used, it should be a breathable type and positioned behind the battens. The batten needs to have a minimum thickness of 25mm. Battens should be fixed into position at a maximum of 500mm centres using a suitable fixing.

All battens need to be flat and levelled against the wall surface; use shims if necessary.

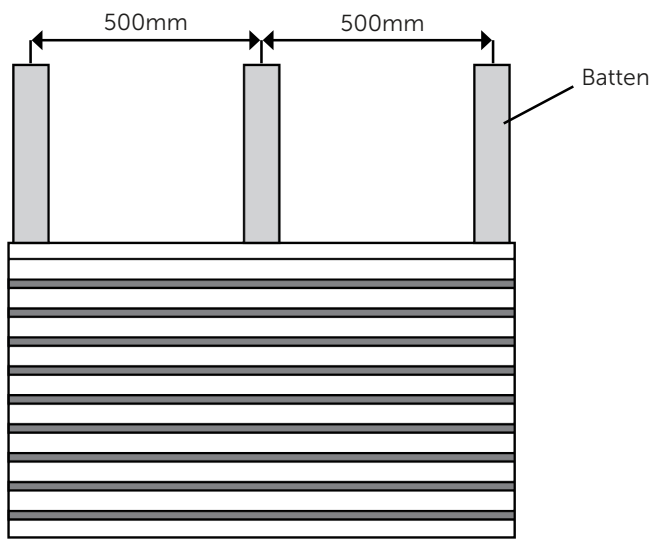

HORIZONTAL INSTALLATION

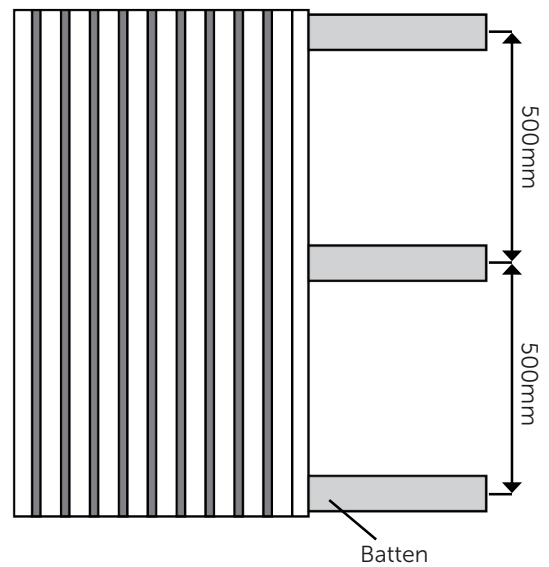

VERTICAL INSTALLATION

FIXING & LOCKING THE CLADDING

Aluminium Cladding Clips should be installed close to each end of a board and at maximum 500mm centres along its length.

The Clip features two holes; one hole is for a Wood Screw to fix the cladding system to the supporting structure and the other is for a Locking Screw to lock the cladding board in place. The composite cladding boards will expand and contract, and to accommodate this movement each should be locked only once. This will allow the board to expand and contract readily from that point.

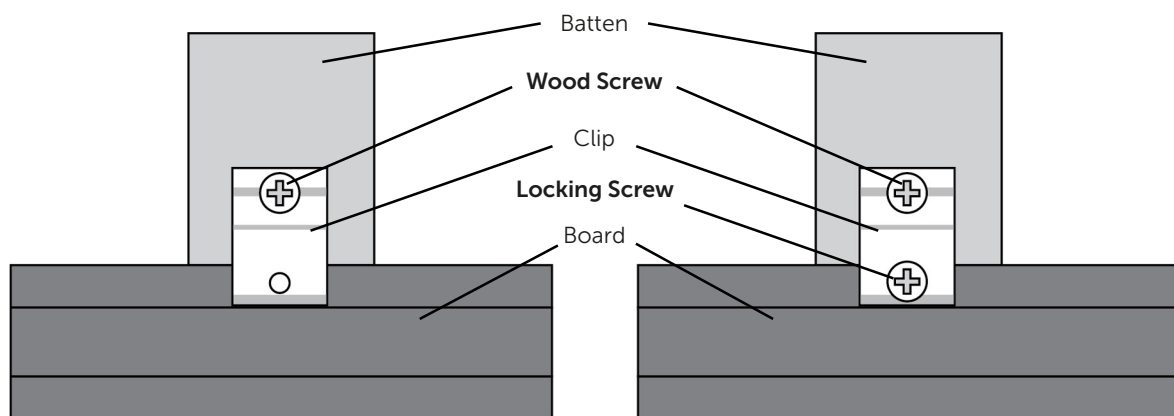

WITHOUT LOCKING SCREW

WITH LOCKING SCREW

(ONCE PER BOARD, ALWAYS PRE-DRILL CLADDING BOARD BEFORE INSERTING LOCKING SCREW)

DO NOT LOCK EVERY CLIP. The general rule of thumb is every cladding board should be locked at one fixing point along its length.

ALWAYS PRE-DRILL CLADDING BOARD. When installing a locking screw, the composite cladding board should be pre-drilled to avoid splitting.

HORIZONTAL INSTALLATION

When installing horizontally, cladding boards should be fixed at 500mm centres and locked at the middle only.

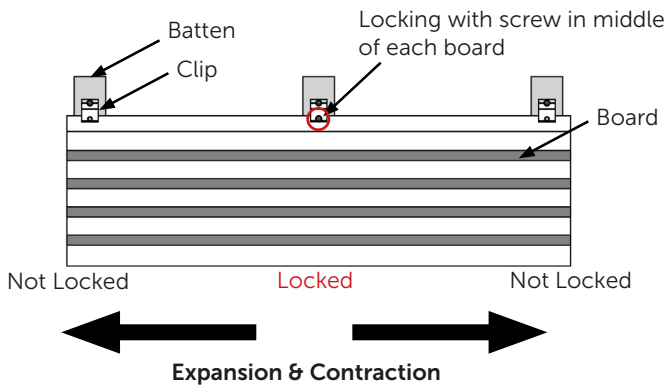

VERTICAL INSTALLATION

When installing vertically, cladding boards should be fixed at 500mm centres and locked at the top only.

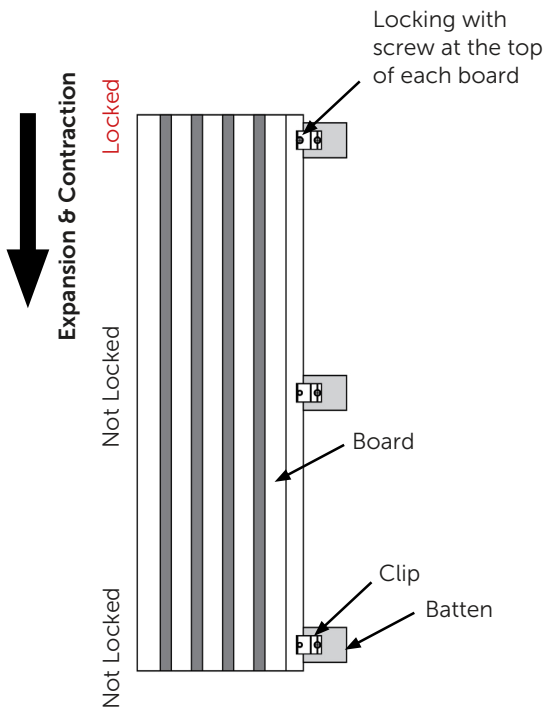

EXPANSION & CONTRACTION VALUES

Composite cladding will expand and contract with changes in temperature. Expansion and contraction are most significant where extreme temperature changes occur.

Fastening adjacent cladding panels according to the gapping requirements noted in the following table accommodates this movement.

GAP REQUIRED BETWEEN BOARDS (IN MM)

LENGTH (METRES)

	1	2.44	2.8	3	3.66	3.9	4	4.88	5.4
-10	2.4	5.9	6.7	7.2	8.8	9.4	9.6	11.7	13.0
-5	2.2	5.4	6.2	6.6	8.1	8.6	8.8	10.7	11.9
0	2.0	4.9	5.6	6.0	7.3	7.8	8.0	9.8	10.8
5	1.8	4.4	5.0	5.4	6.6	7.0	7.2	8.8	9.7
10	1.6	3.9	4.5	4.8	5.9	6.2	6.4	7.8	8.6
15	1.4	3.4	3.9	4.2	5.1	5.5	5.6	6.8	7.6
20	1.2	2.9	3.4	3.6	4.4	4.7	4.8	5.9	6.5
25	1.0	2.4	2.8	3.0	3.7	3.9	4.0	4.9	5.4
30	0.8	2.0	2.2	2.4	2.9	3.1	3.2	3.9	4.3
35	0.6	1.5	1.7	1.8	2.2	2.3	2.4	2.9	3.2
40	0.4	1.0	1.1	1.2	1.5	1.6	1.6	2.0	2.2

INSTALLATION TEMPERATURE (°C)

SLATTED CLADDING - HORIZONTAL INSTALLATION

Step 1: Framing - Measure & chalk the batten position

Step 2: Framing - Batten installation

Step 3: Align and install first fixings

Step 4: Install the Cladding Boards

Step 5: Install the last Boards

Step 6: Finish the walls.

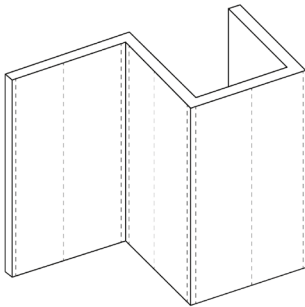

Step 1 - Measure & chalk

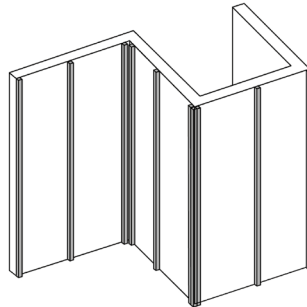

Step 2 - Batten installation

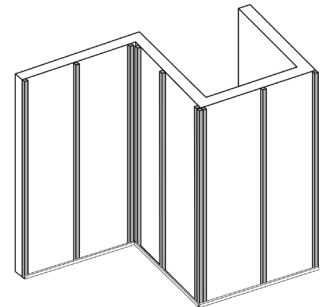

Step 3 - Align and install first fixings

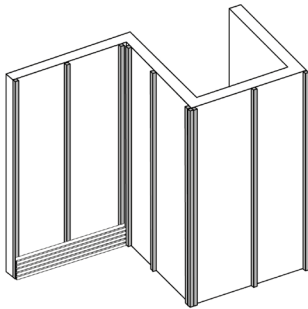

Step 4 - Install the Cladding Boards

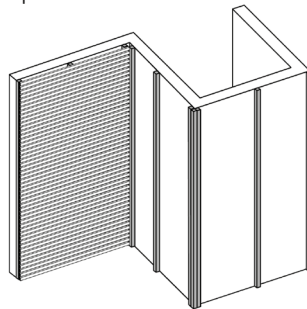

Step 5 - Install the last Boards

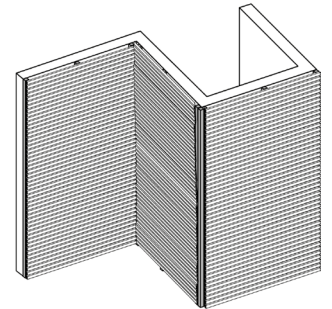

Step 6 - Finish the walls

STEP 1

Measure and chalk the batten position at maximum 500mm centres.

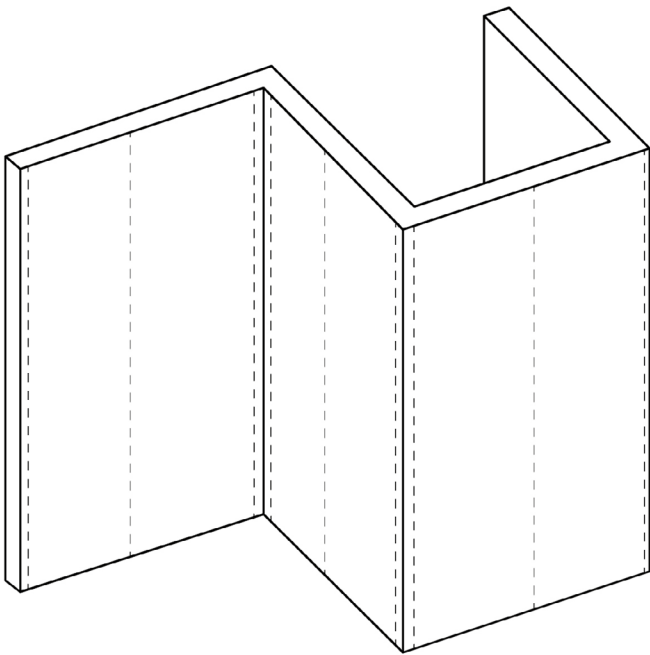

STEP 2

Fix the battens onto the wall with suitable fixings with a maximum spacing of 500mm.

Please note: A minimum gap of 40mm is needed between the batten and the floor.

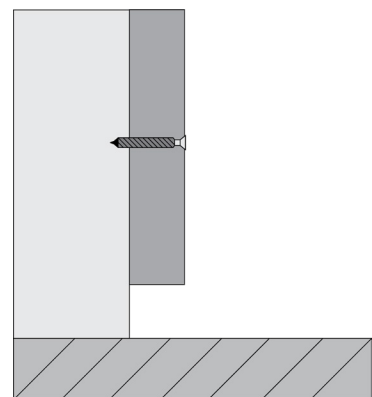
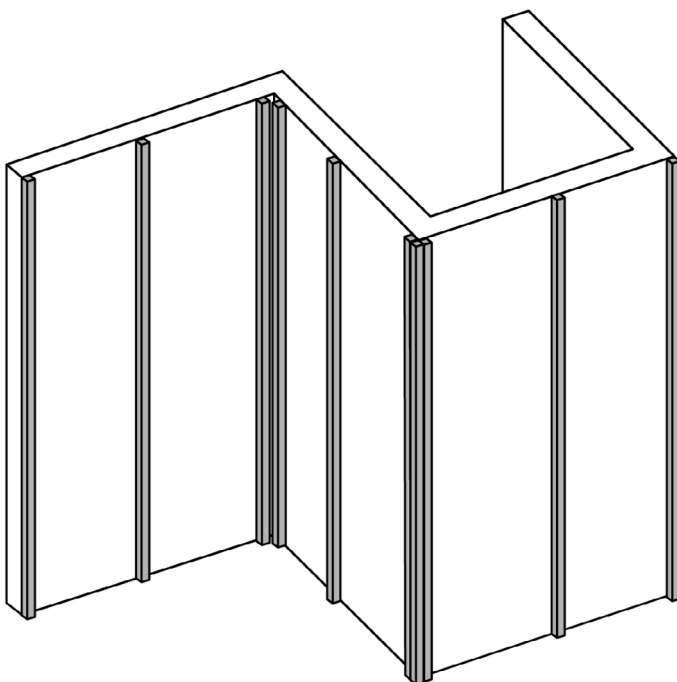

STEP 3

Align and install either Aluminium Cladding Clips or an Aluminium Starter Bar (as shown), at the bottom end of the battens with screws.

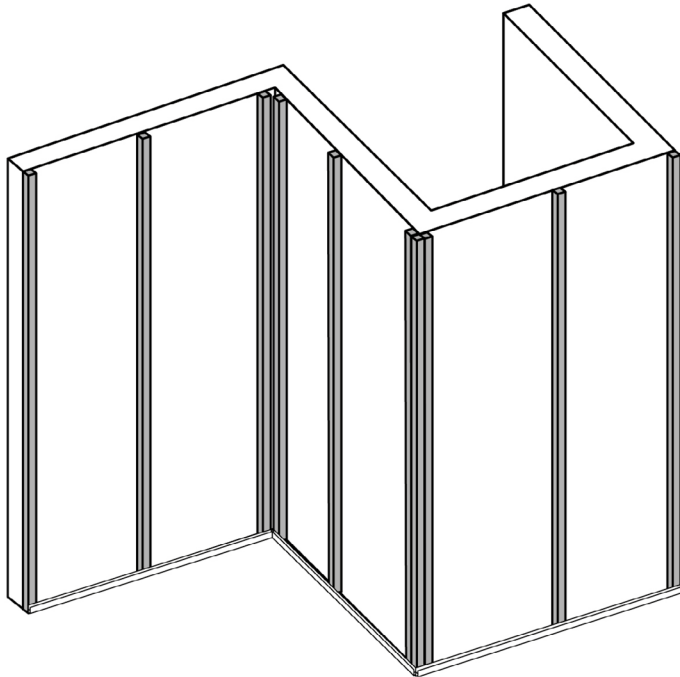

STEP 4

Put the first cladding board over the starter bar/clips and fasten it onto the batten with clips on top edge. The clearance between the cladding board and the floor should be at least 20mm, as shown below:

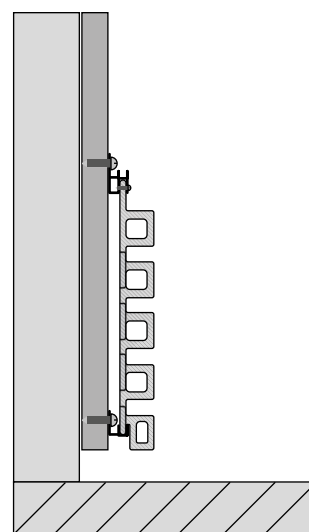
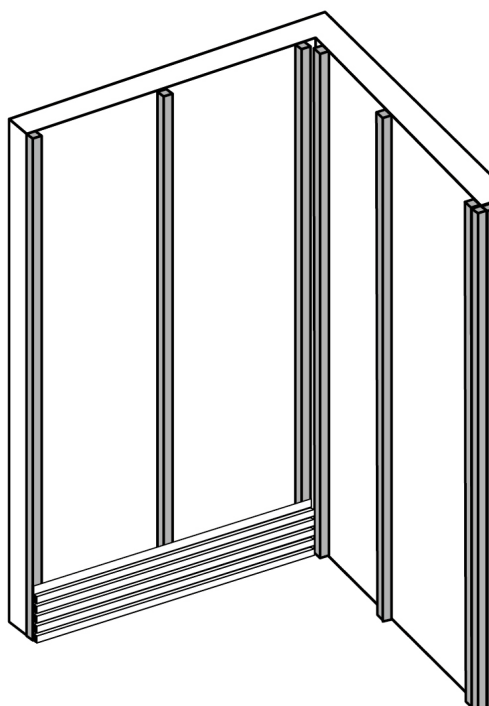

STEP 5

Put the second cladding board over the first boards and fasten with the clips as shown.

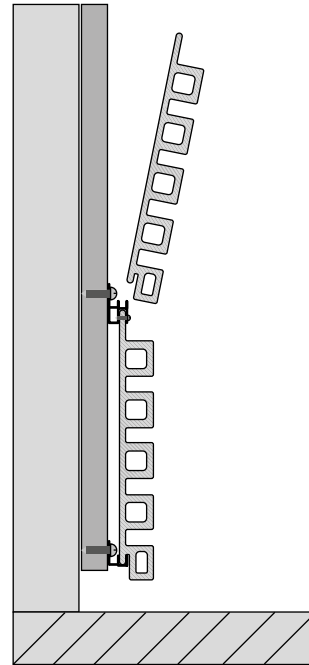
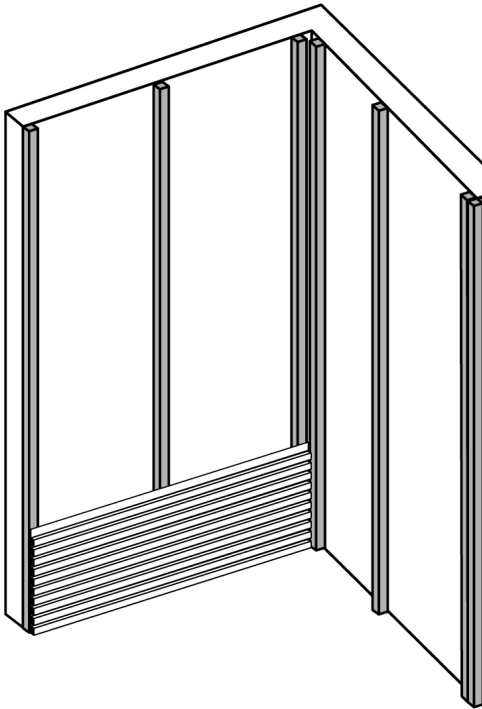

Please note:

Since installation must allow for expansion and contraction due to temperature change, the board must be locked at one fixing point to allow the remaining board to move freely. **When installing horizontally, it is required to lock the clip at the middle of each board.**

Do not lock any other clip for the same board and always pre-drill the composite cladding board when locking.

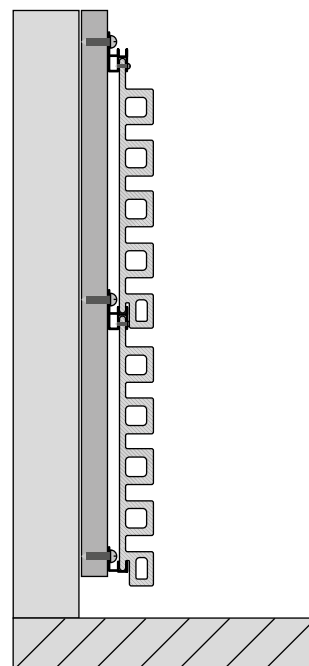
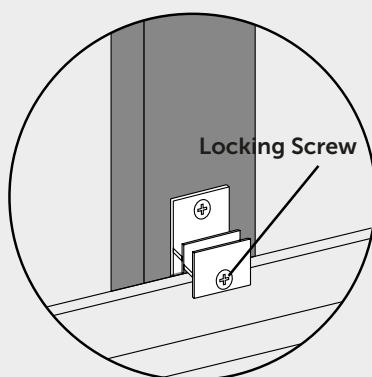

STEP 6

When you reach the final board, measure the distance between the top end of the batten and the cladding board as shown below.

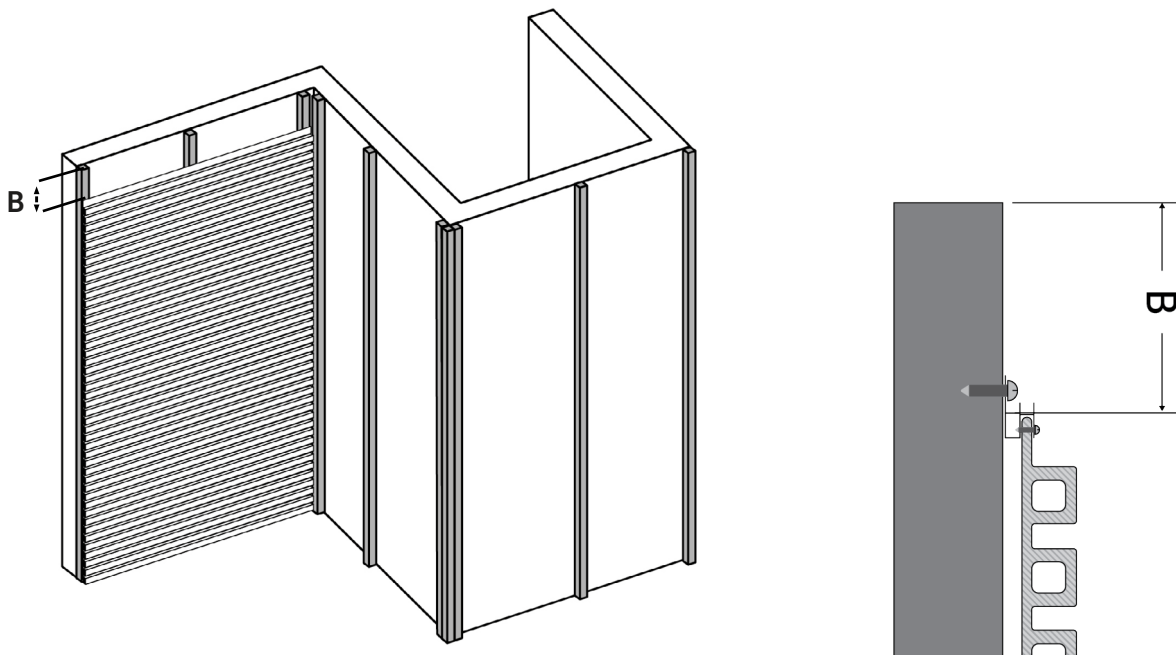

Cut the board as per the measurement. Alternatively, use a relevant trim, such as an End Trim.

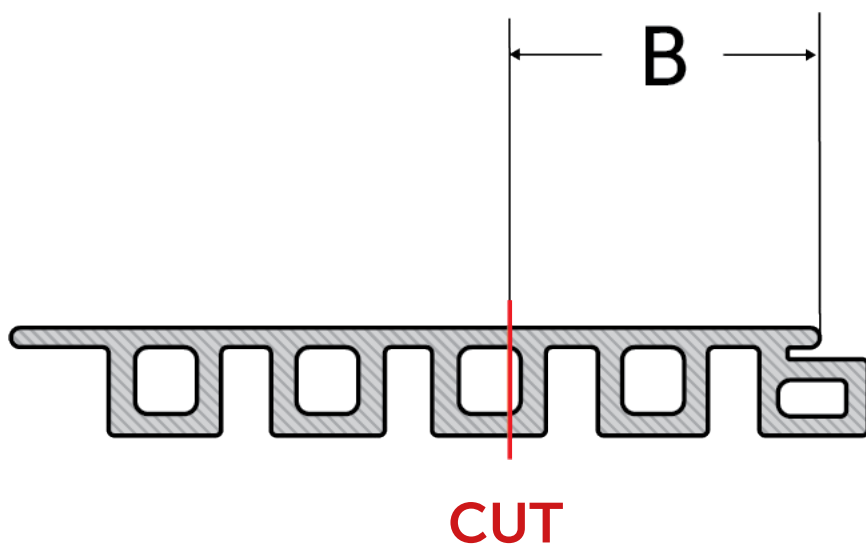

STEP 5

Clip the final cut board in place and then face fix it onto each batten along the length of the board. Colour-coded screws are available.

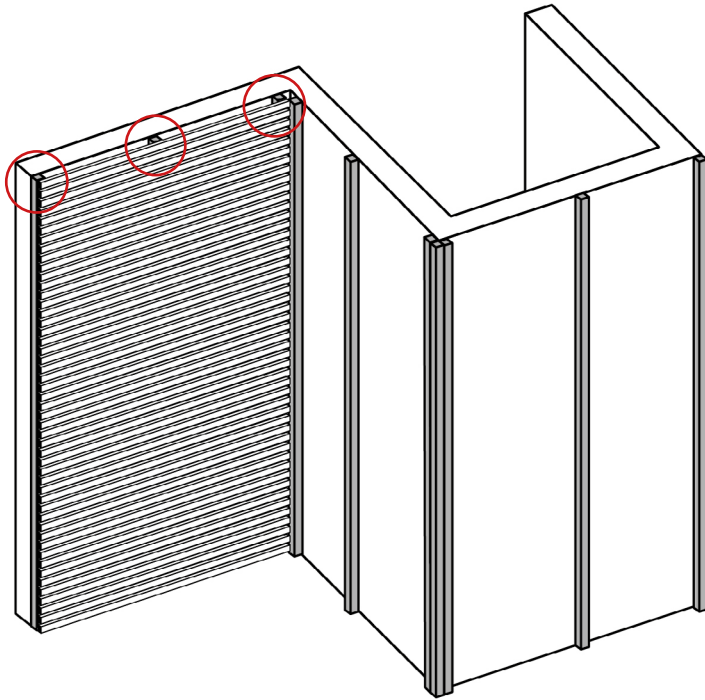

SLATTED CLADDING - VERTICAL INSTALLATION

Step 1: Framing - Measure & chalk the batten position

Step 2: Framing - Batten installation

Step 3: Install the End Trim and the Outside Corner Trim

Step 4: Install the Cladding Boards

Step 5: Install the last Boards

Step 6: Finish the walls.

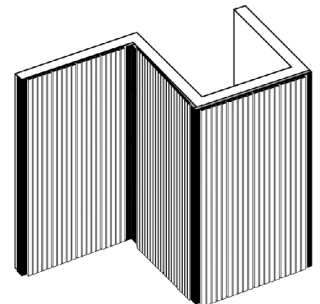
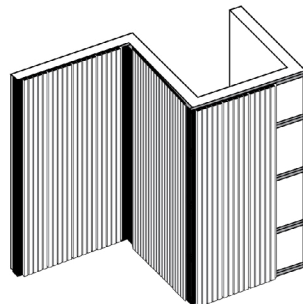
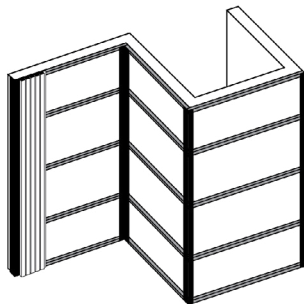
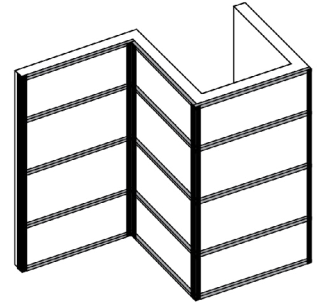
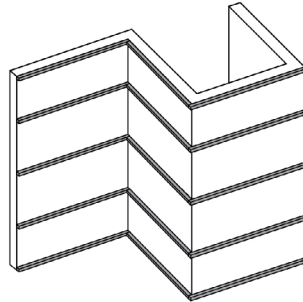
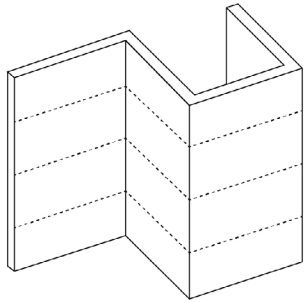

STEP 1

Measure and chalk the batten position at maximum 500mm centres.

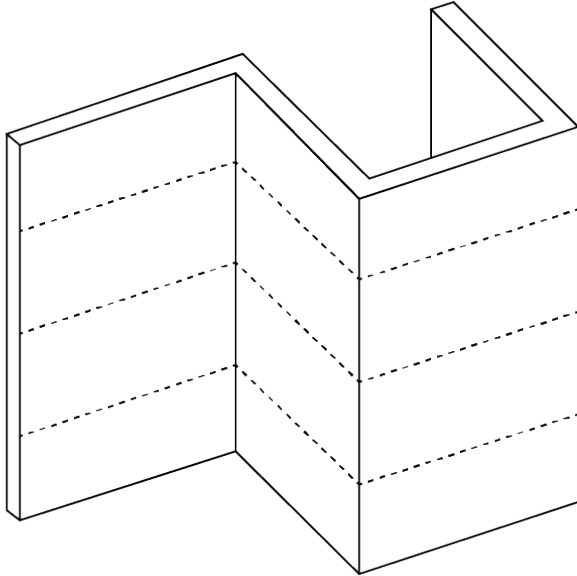

STEP 2

Fix the battens onto the wall with the correct screws with a maximum distance of 500mm as shown below:

Please note: A minimum gap of 40mm is needed between the batten and the floor.

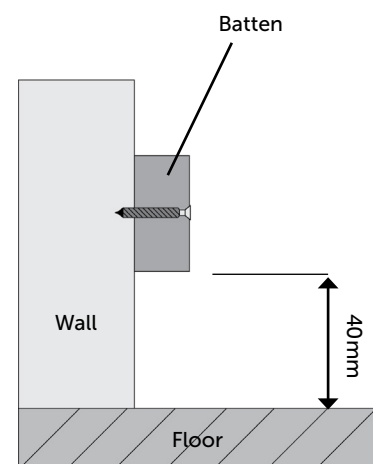
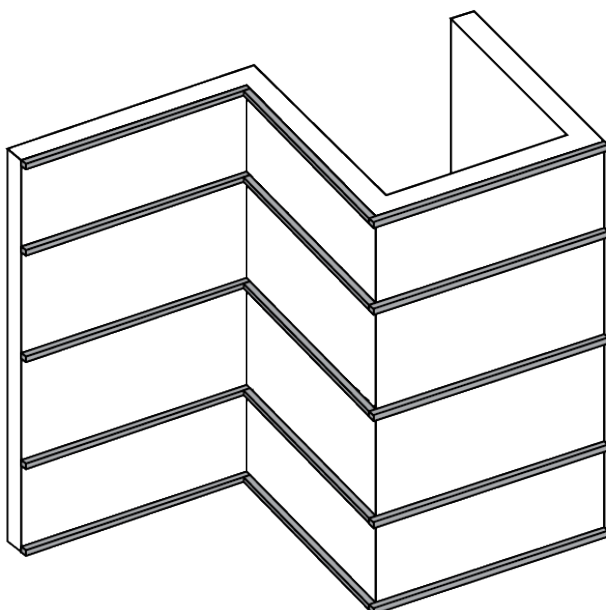

STEP 3

Install the End Trim on the outer most edges and install the Corner Trims at external corners with screws as shown.

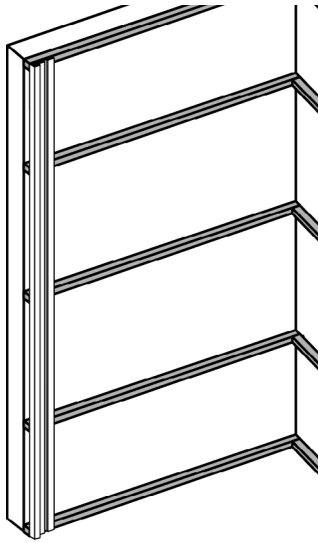

END TRIM

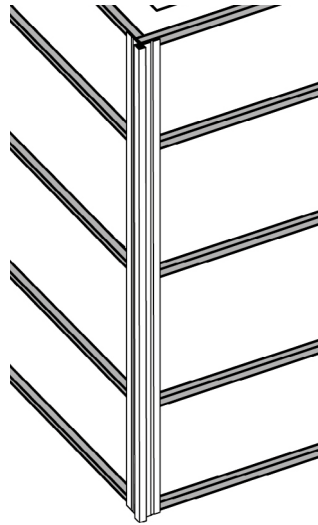

CORNER TRIM

STEP 4

Install the first board from the outermost edge and screw directly into the End Trim. Fix with clips to battens at maximum 500mm vertical centres and lock the board at the top fixing point only.

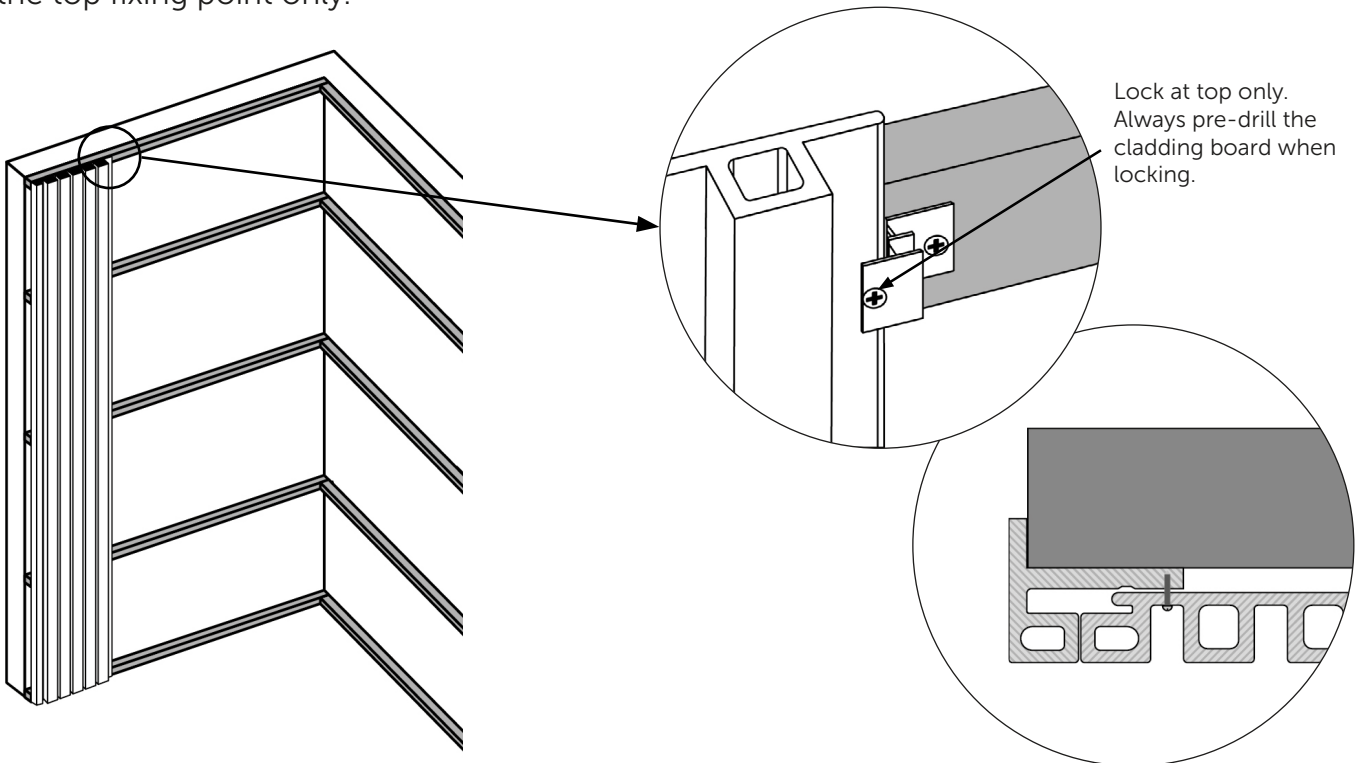

Please note: To allow for expansion and contraction due to temperature change, the board must be locked at only one fixing point to allow the remaining boards to move freely. When installing vertically, it is required to lock the clip at the top of every board as shown. **Do not lock any other clip for the same board and always pre-drill the composite cladding board when locking.**

Put the second cladding board in place and fasten with clips as shown, remembering to lock the top fixing point only.

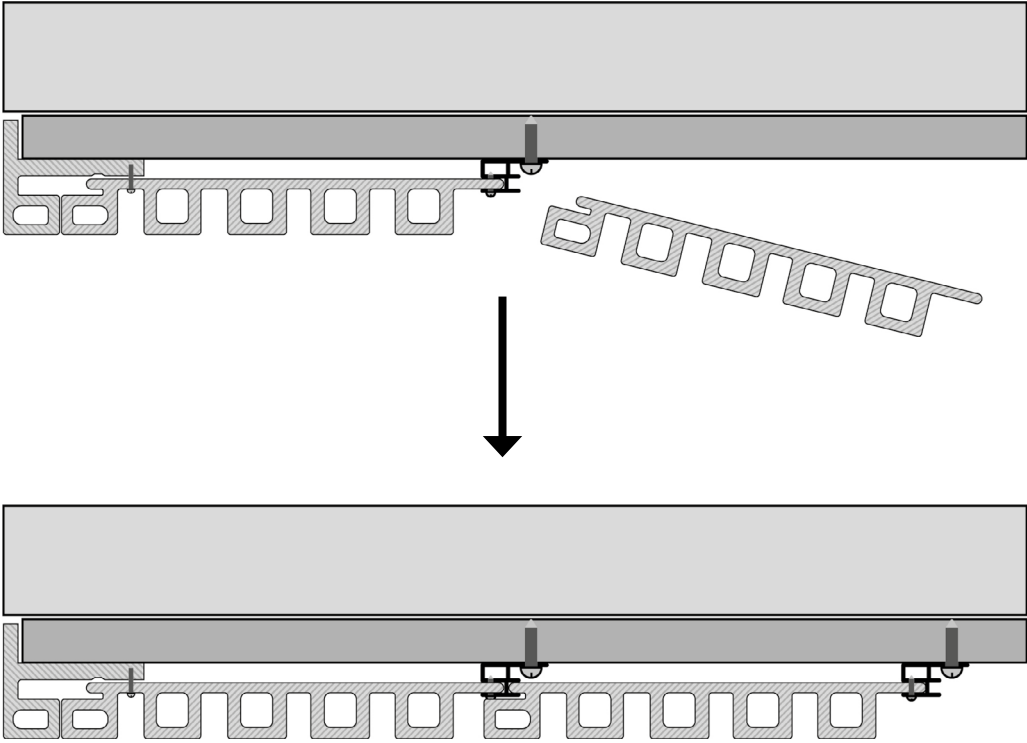
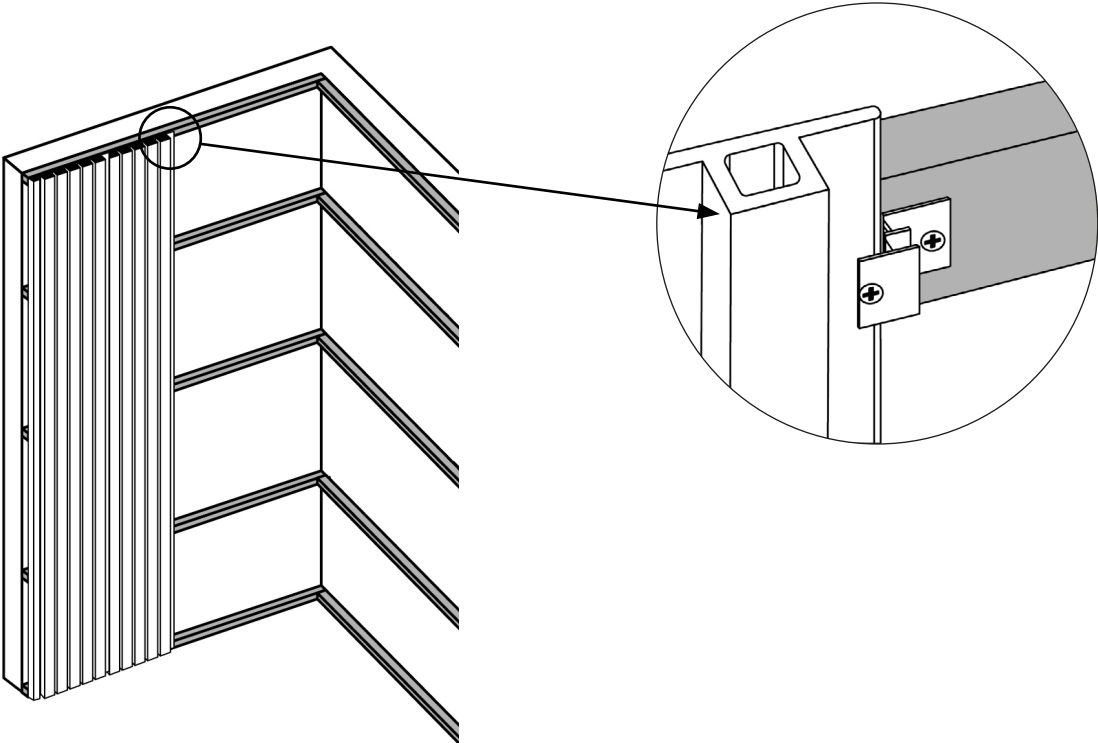

STEP 5

Continue until you reach the last board. Measure the remaining distance to obtain the final board cutting dimensions.

Cut the board to the desired dimensions.

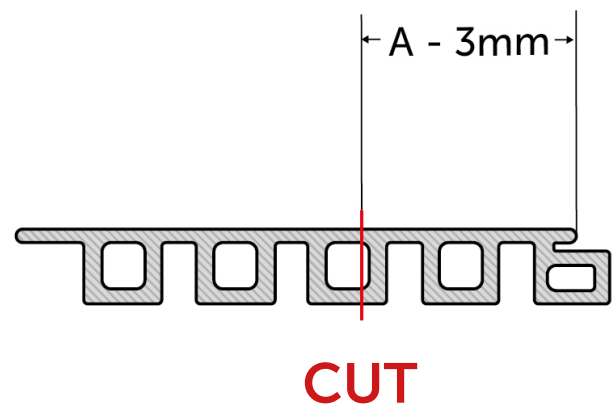
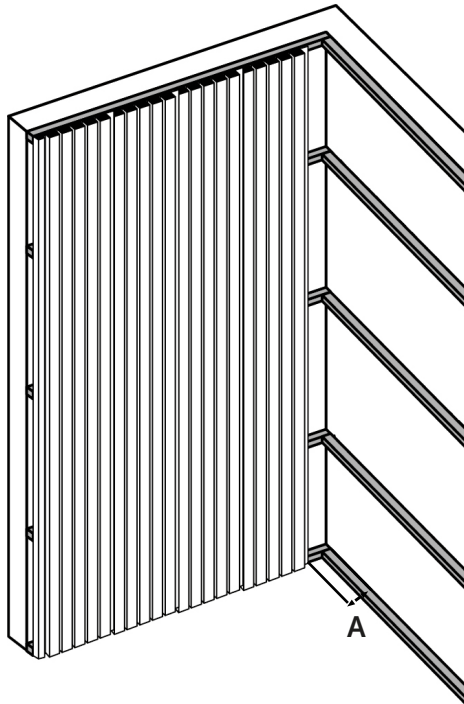

Finally install the cut cladding board into place and face fix onto the batten with screws. Colour-coded screws are available.

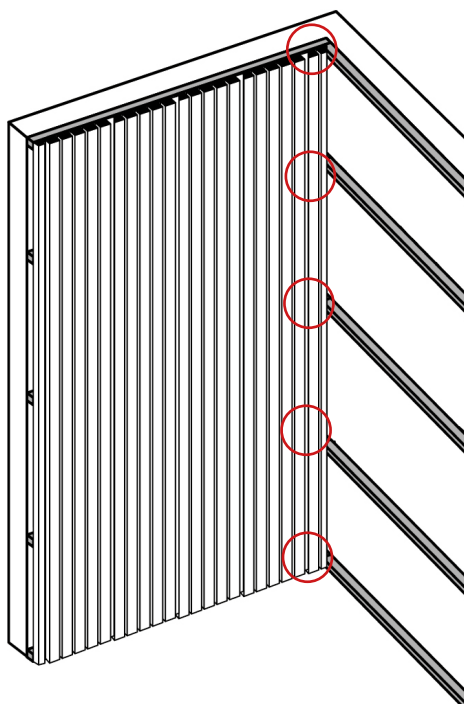

BMARCHITECTURAL

SPECIALISTS IN ARCHITECTURAL SYSTEMS

From homes to workplaces and beyond, we help create inspiring and safe spaces where people thrive.

Our expertise areas include:

- Residential, commercial and anti-terror **Glass Balustrade**
- Canopies, partitions and structural walls of **Frameless Glass**
- Fire-rated, security, slimline and thermally-insulated **Steel Glazing**
- **Class A Fire-Rated Balcony Systems** for safer high-rise living
- Composite and recycled plastic products for transforming **Outdoor Spaces**

Our architectural systems enhance the natural light, feeling of space, views, safety and visual appeal of a property. They also enable design professionals and building owners to meet fall protection, thermal, fire and security regulations with ease.

Contact us to discuss your requirements. We supply new-build and renovation projects, large and small, throughout the UK and Ireland.

T: 0114 254 3226

E: sales@bmarchitectural.com

W: www.bmarchitectural.com

A BARCLAY & MATHIESON LTD COMPANY

BMGROUP

Version 2 | April 2026

BMSTEEL



SPS STEEL
PLATE &
SECTIONS

**BARCLAY &
MATHIESON**

AFG
ANGUS F GUNN LTD

BMDISTRIBUTION