

Vortex® - BM 2400LP Series

The BM 2400LP series are SURFACE mount mounting. The BM 2400LP model uses a miniature LED and a large strip LED for long distance door monitoring and smarter look (see LED feature p3).

The BM 2400LP series needs DC and stabilised power. The voltage (measured at the lock) must be correct for the magnet to retain the armature plate with its highest holding force capacity. When an external pressure is applied, the combined technology of magnetic force and swivel pin held inside the magnet hole by six metal marbles will ensure a holding force of > 15 000 N (~ 1 500 kgf). Cutting the power to the lock will remove the magnetic force and the marbles release themselves from pin head to unlock the door. The Vortex® BM 2400LP works in 12 or 24VDC. A reed contact is integrated for a complete locking monitoring. This monitoring only works if the armature plate is fitted flexibly and if the power supply is correct at the lock input. Another reed contact provides the door status. The exit button (or keypad, prox reader...) must be wired on 12VDC (or 24VDC), not on the input wiring of power supply.

Also, this Vortex lock is equipped with a contact with 1 output able to detect any pressure on the locked door. This contact could be connected to an alarm system or local alarm to warn BEFORE the access is opened without authorisation. A built-in buzzer will sound simultaneously.

The PSU output must not be connected to the earth but isolated to avoid any kind of electric sparks, therefore damaging the lock and its surfaces.

Wiring and Power Input

NO - DSS (BLUE)		NO - DSS (BLUE)	30 VDC max 0.3 A max, 10 W max
Buzzer Enabled - Close		NO (PURPLE)	EW, 50VDC, 0.3A max
Buzzer Disabled - Open		COM (ORANGE)	
NO-LSS (YELLOW)		NC (PINK)	30 VDC max 0.3 A max, 10 W max
12/24 VDC 12VDC/0.36A, 24VDC/0.18A		-(BLACK)	

To prevent irreversible damage to the unit, ensure that wiring is connected correctly before supplying power to the mechanical electro magnet.

Important safety precaution

Secure firmly the **BM 2400LP** Mechanical Electro Magnet on the doorframe. The provided screws must be used in accordance with the frame or support material. Also, the screws must be checked periodically to avoid looseness.

Maintenance

The surface of contact between the mechanical electro magnet and the armature plate must be kept cleaned. Surfaces should be cleaned periodically with a non-abrasive cleaner. Do not use cleaning chemical products such as cleaning solvents or varnish. This will lead to serious problems releasing the armature plate from the magnet, damaging the mechanism and causing safety problems.

Trouble Shooting

PROBLEM	POSSIBLE CAUSE	SOLUTION
Door will not lock	Not enough DC voltage.	Check power at lock and wiring connection.
	Wrong wire connection.	Check wiring and refer to wiring instruction.
	The screw centre is bad positioned compared to the magnet.	Screw or contact supplier.
Holding Force reduced	Bad physical contact between armature plate and magnet surface.	Make sure than surface contact is cleaned and well aligned with the armature plate
There is a delay in door release when power off.	The power switch-off is disturbed by the power supply stabilisation.	The power cut must be done between the PSU and lock. Not at the AC input of the PSU.

Note: From factory, the voltage setting is 24VDC. For 12 VDC installation, please select the jumper correctly.

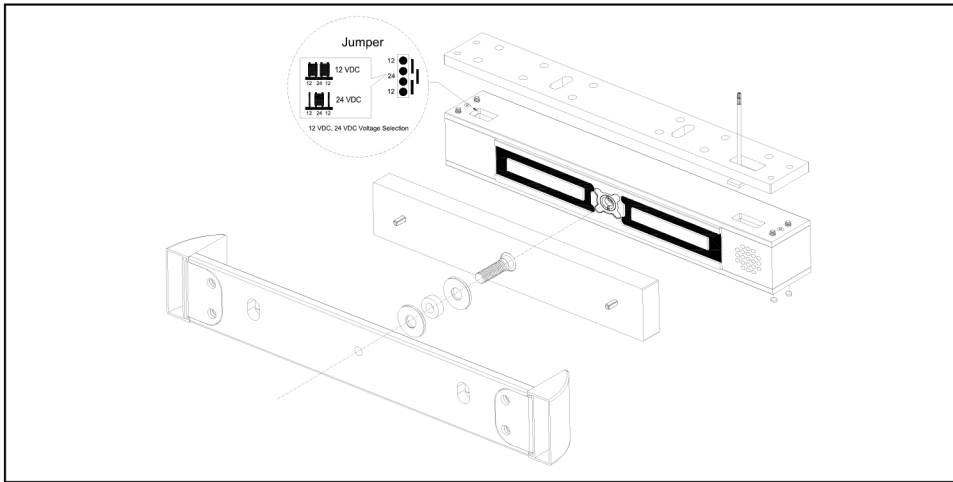

Swivel Pin Assembly

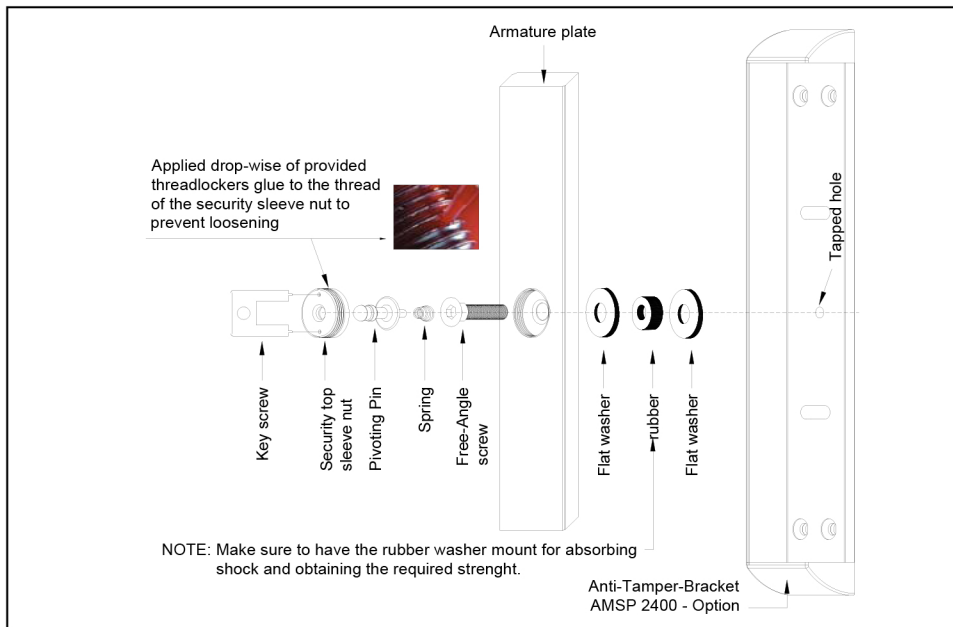

To assure a solid locking from the magnet and its armature plate, you need to mount the latter with FLEXIBILITY with help from the rubber washer supplied. A over tighten central screw or not enough power supply are the two main reasons why a magnet will not work with efficiency.

Light feature

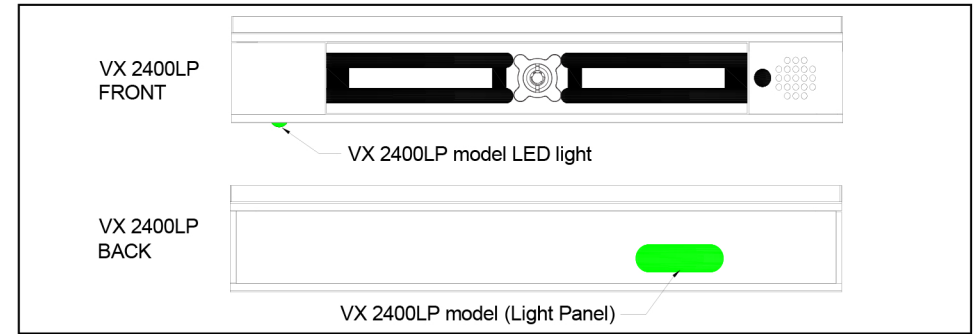

Installation dimension

